

Q1.

- (a) Draw a diagram to show how 1.5 V cells should be connected together to give a potential difference of 4.5 V.

Use the correct circuit symbol for a cell.

(2)

A student built the circuit shown in the diagram below.

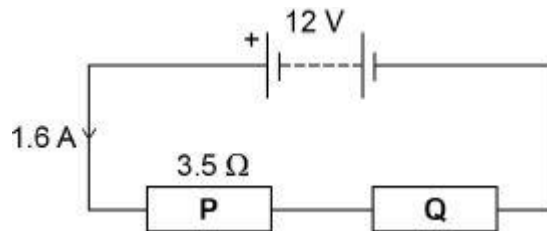

- (b) Calculate the total resistance of the circuit in the diagram above.

Use the equation:

$$\text{resistance} = \frac{\text{potential difference}}{\text{current}}$$

Total resistance = _____ Ω

(2)

(c) The resistance of **P** is 3.5Ω .

Calculate the resistance of **Q**.

Resistance of **Q** = _____ Ω

(1)

(d) The student connects the two resistors in the diagram above in parallel.

What happens to the total resistance of the circuit?

Tick **one** box.

It decreases

It increases

It does not change

(1)

Give a reason for your answer.

(1)

(Total 7 marks)

Q2. The diagram shows the circuit used to obtain the data needed to plot the current-potential difference graph for a filament lamp.

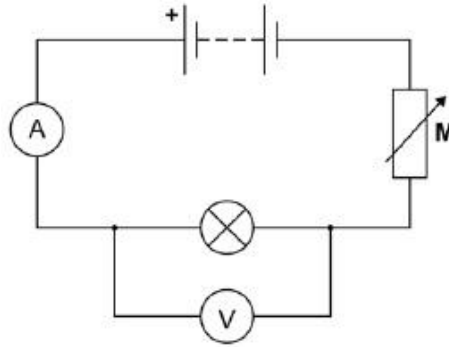

(a) Why is component **M** included in the circuit?

To keep the current constant.

To keep the potential difference constant.

To vary the current.

(1)

(b) Why does the resistance of the lamp increase as the potential difference across the lamp increases?

(1)

(c) The potential difference across the lamp is 12.0 V

Calculate the energy transferred by the lamp when 8.5 C of charge flows through the lamp.

Use the equation:

$$\text{energy transferred} = \text{charge flow} \times \text{potential difference}$$

Energy transferred = _____ J

(2)

- (d) The table gives data about two types of lamp that householders may use in their homes.

Type of lamp	Energy efficiency	Mean lifetime in hours
Halogen	10%	2000
LED	90%	36000

Both types of lamp produce the same amount of light.

Describe the environmental advantages of using the LED lamp compared with the halogen lamp.

(2)
(Total 6 marks)

Q3.

The plug of an electrical appliance contains a fuse.

- (a) What is the correct circuit symbol for a fuse?

Tick **one** box.

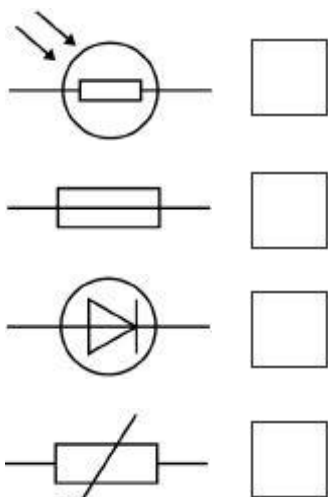

(1)

- (b) The appliance is connected to the mains electrical supply. The mains potential difference is 230 V.

Calculate the energy transferred when 13 C of charge flows through the appliance.

Use the equation:

$$\text{energy transferred} = \text{charge flow} \times \text{potential difference}$$

$$\text{Energy transferred} = \text{_____} \text{ J}$$

(2)

The diagram below shows the structure of a fuse.

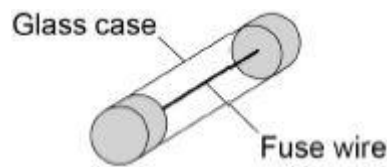

- (c) Write down the equation that links charge flow, current and time.

(1)

- (d) The fuse wire melts when 1.52 coulombs of charge flows through the fuse in 0.40 seconds.

Calculate the current at which the fuse wire melts.

$$\text{Current} = \text{_____} \text{ A}$$

(3)

- (e) The mass of the fuse wire is 0.00175 kg. The specific latent heat of fusion of the fuse wire is 205 000 J/kg.

Calculate the energy needed to melt the fuse wire.

Use the Physics Equations Sheet.

Energy = _____ J

(2)

(Total 9 marks)

- Q4.** (a) Complete the sentence. Choose answers from the box.

charge	potential difference	power	temperature	time
---------------	-----------------------------	--------------	--------------------	-------------

The current through an ohmic conductor is directly proportional to the _____ across the component, provided that the _____ remains constant.

(2)

- (b) **Figure 1** shows a current – potential difference graph for a filament lamp.

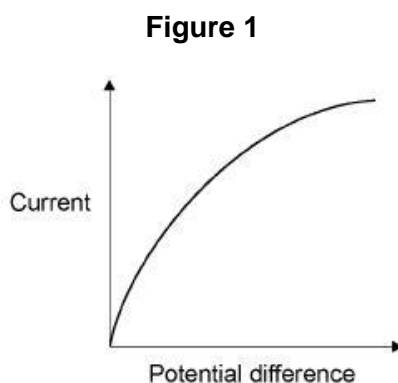

Explain how the resistance of a filament lamp changes as the potential difference across it increases.

(3)

- (c) Many householders are replacing their filament lamps with LED lamps which are more energy efficient.

What does more energy efficient mean?

(1)

A Light Dependent Resistor (LDR) is used to turn on an outside lamp when it gets dark.

Part of the circuit is shown in **Figure 2**.

Figure 2

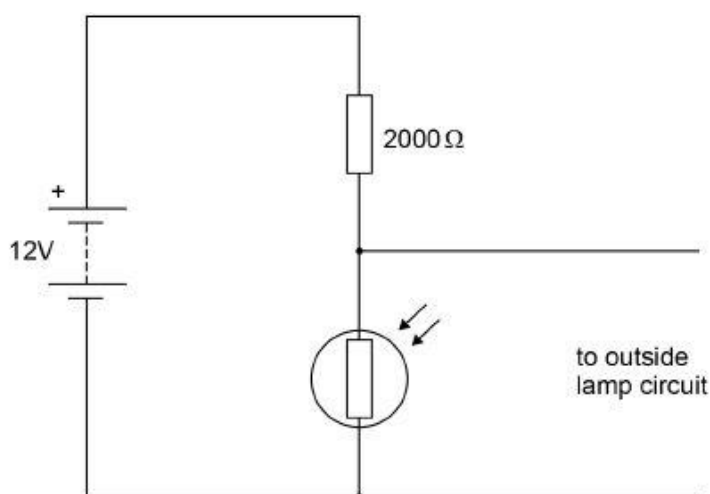

- (d) The light intensity decreases.

What happens to the potential difference across the LDR and the current in the LDR?

Potential difference _____

Current _____

(2)

- (e) What is the resistance of the LDR when the potential difference across it is 4 V?

Give a reason for your answer.

Explain your answer.

Resistance = _____ Ω

Reason _____

(2)

- (f) Calculate the current through the LDR when the resistance of the LDR is $5000\ \Omega$.
Give your answer to 2 significant figures.

Current = _____ A

(4)

(Total 14 marks)

Q5.

A student investigated how the resistance of a piece of nichrome wire varies with length.

Figure 1 shows part of the circuit the student used.

Figure 1

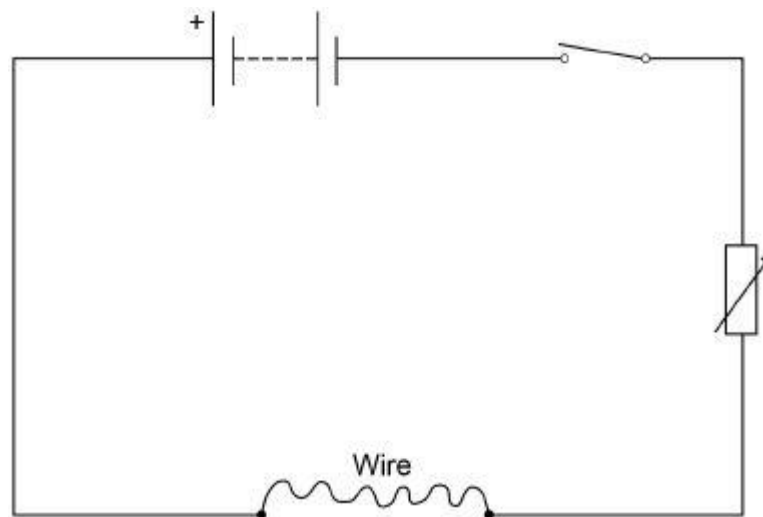

- (a) Complete **Figure 1** by adding an ammeter and a voltmeter.

Use the correct circuit symbols.

(3)

- (b) Describe how the student would obtain the data needed for the investigation.

Your answer should include a risk assessment for **one** hazard in the investigation.

(6)

- (c) Why would switching off the circuit between readings have improved the accuracy of the student's investigation?

Tick **one** box.

The charge flow through the wire would not change.

The potential difference of the battery would not increase.

The power output of the battery would not increase.

The temperature of the wire would not change.

(1)

- (d) The student used crocodile clips to make connections to the wire.
They could have used a piece of equipment called a 'jockey'.

Figure 2 shows a crocodile clip and a jockey in contact with a wire.

Figure 2

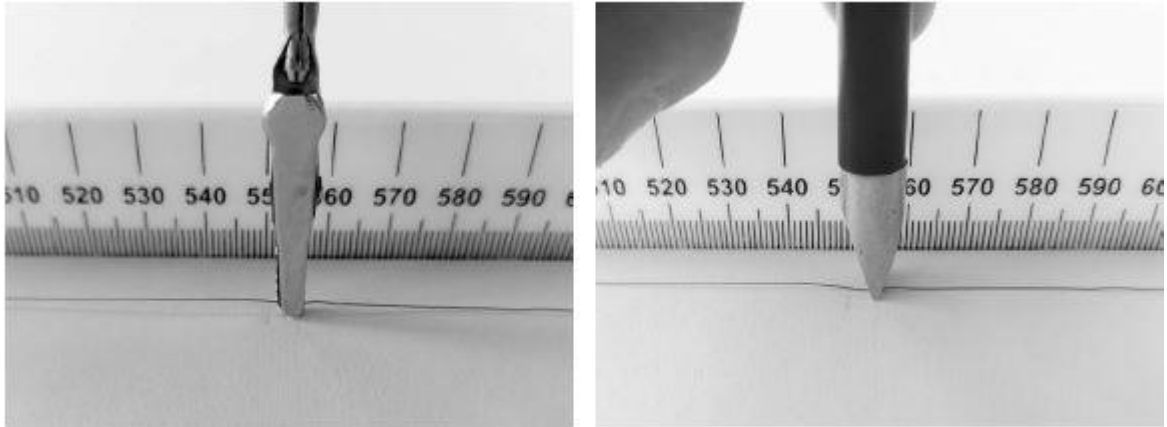

Crocodile clip

Jockey

How would using the jockey have affected the accuracy and resolution of the student's results compared to using the crocodile clip?

Tick **two** boxes.

The accuracy of the student's results would be higher.

The accuracy of the student's results would be lower.

The accuracy of the student's results would be the same.

The resolution of the length measurement would be higher.

The resolution of the length measurement would be lower.

The resolution of the length measurement would be the same.

(2)
(Total 12 marks)

Q6.

The photograph below shows a coffee machine. The coffee machine uses an electric element to heat water.



- (a) The coffee machine has a metal case.

Why would it be dangerous for the live wire of the electric cable to touch the metal case?

(1)

- (b) The power output of the coffee machine is 2.53 kW.

The mains potential difference is 230 V.

Calculate the current in the coffee machine.

Current = _____ A

(3)

(c) The coffee machine heats water from 20 °C to 90 °C.

The power output of the coffee machine is 2.53 kW.

The specific heat capacity of water is 4200 J/kg °C.

Calculate the mass of water that the coffee machine can heat in 14 seconds.

Mass = _____ kg

(5)

(Total 9 marks)

Mark schemes

Q1.

- (a) correct circuit symbol

1

3 cells joined in series in correct orientation

e.g.

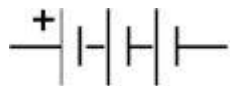

ignore absence of + symbol

1

- (b) $R = \frac{12}{1.6}$

1

$$R = 7.5 (\Omega)$$

1

an answer of 7.5 (Ω) scores 2 marks

- (c) 4.0 (Ω)

allow their answer to part (b) – 3.5 correctly calculated

1

- (d) it decreases

1

the current would be higher (for the same p.d.)

reason only scores if correct box is chosen

or

more than one path for charge to flow

allow current for charge

or

total resistance is always less than the smallest individual resistance

1

[7]

Q2.

- (a) to vary the current.

1

- (b) the temperature of the filament increases

allow the filament heats up

1

- (c) $E = 12 \times 8.5$

1

$$E = 102 \text{ (J)}$$

an answer of 102 (J) scores 2 marks

1

(d) (LED lamp)

longer lifetime (per lamp)

1

wastes less energy

or

lower input energy (for same light energy output)

1

[6]

Q3.

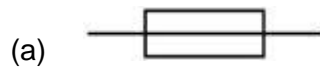

1

(b) $E = 13 \times 230$

1

$$E = 2990 \text{ (J)}$$

1

an answer 2990 (J) scores 2 marks

(c) charge flow = current \times time

allow $Q = It$

1

(d) $1.52 = I \times 0.40$

1

$$I = \frac{1.52}{0.40}$$

1

$$I = 3.8 \text{ (A)}$$

1

an answer of 3.8 (A) scores 3 marks

(e) $E = 0.00175 \times 205\,000$

1

$$E = 359 \text{ (J)}$$

allow an answer that rounds to 360 (J) for 2 marks

1

an answer of 359 (J) scores 2 marks

[9]

- Q4. (a)** potential difference
allow p.d.
allow voltage 1
- temperature 1
- in this order only*
- (b) the current increases (when the potential difference increases) 1
- (which) causes the temperature of the filament to increase 1
- (so) the resistance increases
*do **not** accept resistance increases and then levels off* 1
- (c) a higher proportion / percentage of the (total) power / energy input is usefully transferred
wastes less energy is insufficient
- or**
 higher (useful) power / energy output for the same (total) power / energy input 1
- (d) potential difference increases 1
- current decreases 1
- (e) 1000 (Ω)
reason only scores if $R = 1000 (\Omega)$ 1
- potential difference is shared in proportion to the resistance
allow a justification using a correct calculation 1
- (f) $12 = I \times 7000$ 1
- $I = \frac{12}{7000}$ 1
- $I = 1.71 \times 10^{-3} \text{ (A)}$
*an answer that rounds to $1.7 \times 10^{-3} \text{ (A)}$ scores **3** marks* 1
- $I = 1.7 \times 10^{-3} \text{ (A)}$
this answer only
- or**
 $I = 0.0017 \text{ (A)}$

an answer of 2.4×10^{-3} (A) scores 2 marks
 if no other marks scored allow 1 mark for calculation of total
 resistance (7000Ω)

1

an answer of 1.7×10^{-3} (A) scores 4 marks

[14]

Q5. (a) ammeter and voltmeter symbols correct

1

voltmeter in parallel with wire

1

ammeter in series with wire

1

(b) **Level 3:** The method would lead to the production of a valid outcome. All key steps are identified and logically sequenced.

5–6

Level 2: The method would not necessarily lead to a valid outcome. Most steps are identified, but the method is not fully logically sequenced.

3–4

Level 1: The method would not lead to a valid outcome. Some relevant steps are identified, but links are not made clear.

1–2

No relevant content

0

Indicative content

- length measured
- length varied
- current measured
- potential difference measured
- repeat readings
- calculate resistance for each length
- $\text{resistance} = \frac{\text{potential difference}}{\text{current}}$
- plot a graph of resistance against length
- hazard: high current
- may cause wire to melt / overheat
- may cause burns (to skin)
- use low currents

(c) the temperature of the wire would not change

1

(d) the accuracy of the student's results would be higher

1

the resolution of the length measurement would be higher

1

[12]

Q6.

- (a) risk of electric shock (if someone touched the case)
allow risk of electrocution (if someone touched the case) 1

- (b) $2530 = I \times 230$
this mark may be awarded if P is incorrectly / not converted 1

$$I = \frac{2530}{230}$$

this mark may be awarded if P is incorrectly / not converted 1

$$I = 11 \text{ (A)}$$

this answer only
an answer of 0.011 (A) scores 2 marks
an answer of 11 (A) scores 3 marks 1

- (c) $E = 2530 \times 14$
this mark may be awarded if P is incorrectly / not converted 1

$$E = 35\,420 \text{ (J)}$$

this answer only 1

$$35\,420 = m \times 4200 \times 70$$

allow their calculated $E = m \times 4200 \times 70$ 1

$$m = \frac{35\,420}{4200 \times 70}$$

allow $m = \frac{\text{their calculated } E}{4200 \times 70}$ 1

$$m = 0.12 \text{ (kg)}$$

allow an answer that is consistent with their calculated value of E 1

[9]